

DISCOVER.



quantum
systems

quantum
systems

™ Trinity is a registered trademark of Quantum-Systems GmbH.
™ SCORPION and VECTOR are registered trademarks of Quantum-Systems GmbH.
Copyright © 2021 Quantum-Systems GmbH. All rights reserved.
Document number: 210505_QS_Brochure_A4_V013
Quantum-Systems GmbH • Dornierstrasse 11 • 82205 Gilching • Germany
www.quantum-systems.com

CONTENT

04 ———. About Quantum-Systems

10 ———. Trinity F90+

20 ———. Vector & Scorpion

28 ———. Auterion

30 ———. QBase 3D

34 ———. Customer Support



ABOUT QUANTUM- SYSTEMS



ABOUT QUANTUM-SYSTEMS

Who we are. Our passion. Our mission.

Quantum-Systems GmbH, founded in Munich in 2015, specializes in the development, design, and production of small Unmanned Aircraft Systems (sUAS).

Our sUAS combine eVTOL (electrical vertical take-off and landing) capabilities with long range utilizing electrical and aerodynamic efficiency. We continuously integrate high precision sensors into our systems for increased aerial data intelligence. Using these methods, we are transforming decision making processes for the professional user in both the commercial and governmental sector.

After starting research in 2008 in the field of autonomous flight systems, Florian Seibel and the founding team successfully completed the first automatic transition in 2012. The first serialized eVTOL fixed-wing system was launched to the commercial marketplace in 2016. Since then, it has been our priority to successfully combine the benefits of helicopters and airplanes into our innovative and patented automatic transition aircrafts.



Florian Seibel
CEO, Co-founder

Our sUAS can cover an area of up to 700 hectares with just one flight. This is a substantially larger area than a regular multi-rotor drone can cover, while still maintaining systems that are equally easy to control and to operate.

CEO Florian Seibel: "Our passion is the continuous development of industry leading VTOL aircrafts. These easy to operate systems serve a wide range of customers. Our drones provide data for the agricultural, mining and construction industries, and serve the governmental and security forces. While the full potential and benefits that we can deliver aren't fully exploited yet by the markets, we will further shape the future of unmanned aviation. Our path is clear: we will be the market leader in eVTOLs."

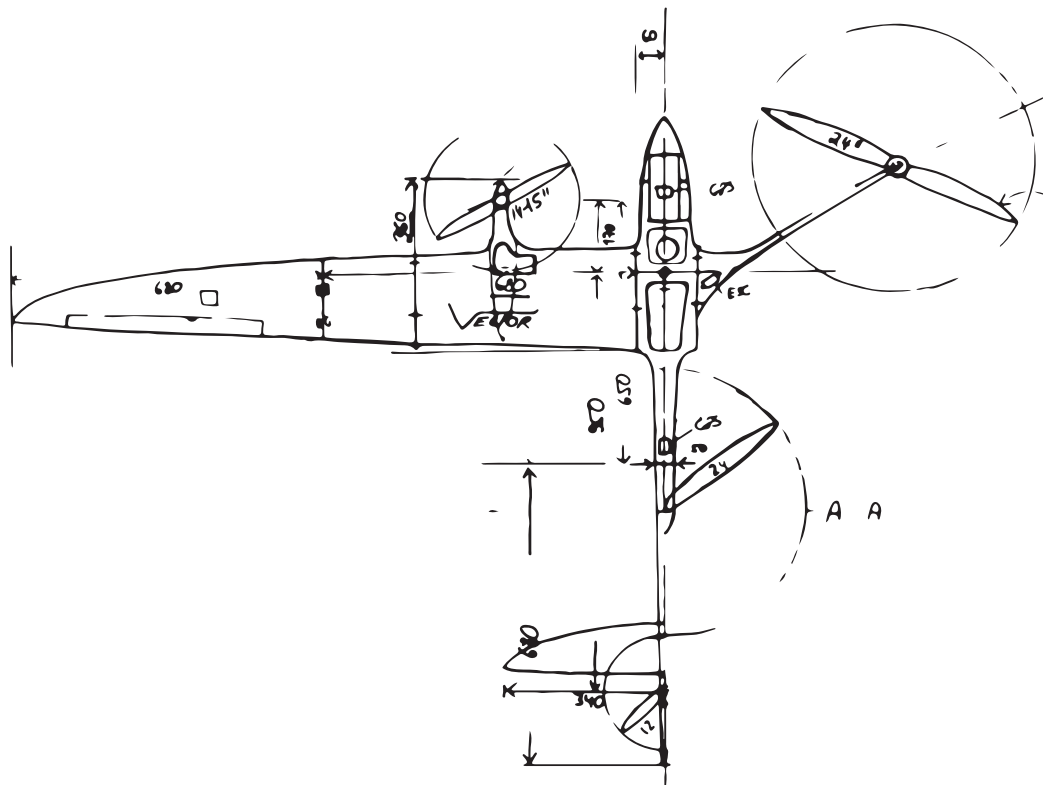

First draft of
Quantum-Systems
Vector and Scorpion UAS

eVTOL INNOVATION

A drone is a drone? It's not that simple.

The Quantum-Systems eVTOL fixed-wing sUAS unite the convenient handling of a multi-rotor drone and the efficient aerodynamics of an airplane into one system - making them unique.

"Automatic transition aircraft" is how Quantum-Systems calls this innovative and patented category of drones. After the vertical take-off and reaching the desired transition altitude, the drone has a short phase of acceleration. During this transition phase, the rotors, driven by electric motors, swivel from the vertical take-off position to a horizontal flight position. The patent for this innovative swivel mechanism and the unique transition technology was granted in 2012.

Our sUAS fly as efficiently as a fixed-wing airplane but allow for the easy vertical take-off and landing like a multi-rotor drone. No runway and no extra equipment are needed for take-off or landing. They land smoothly and controlled on their shock absorbing landing gear. This means reduced harm on the sUAS and sensors for an extended product life.

All our systems are designed, engineered and manufactured in Germany. We operate out of our Headquarter in Gilching, close to Munich, ensuring short communication lines between the key functions.

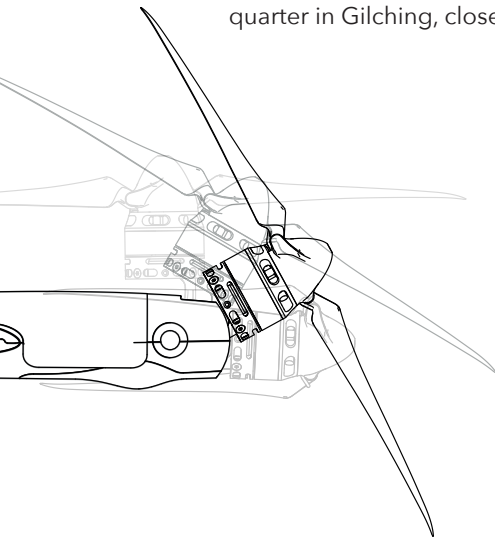

BENEFITS

- Made in Germany
- Take-off and landing in confined areas
- Long flight times, large area coverage
- Survey grade payloads

FLIGHT PHASES

of Quantum-Systems eVTOL fixed-wing systems

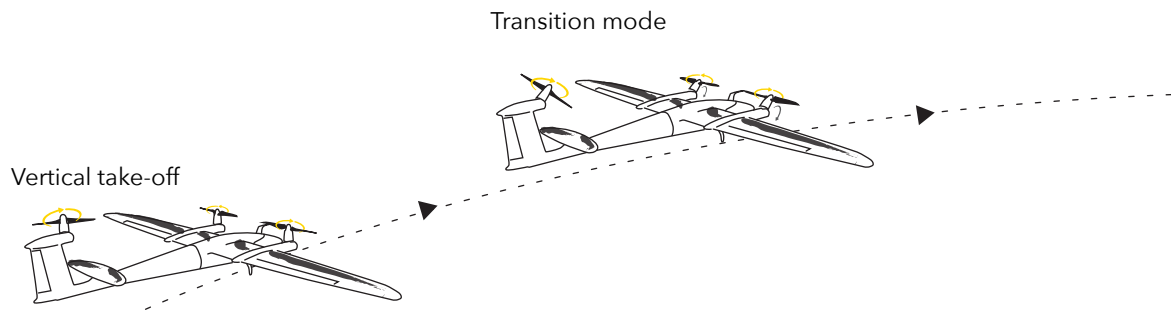

Vertical take-off. In hover mode the electric motors are vertically positioned. All three motors operate. Front motors are optimized for hover and climb.

Transition mode. In transition mode the electric motors and rotors tilt downwards into horizontal position for cruise flight mode. When preparing for landing they swivel back to their vertical position.



Transition technology

Registration 01.06.2012
 Registered Publication 24.12.2013
 Patent numbers DE201210104783

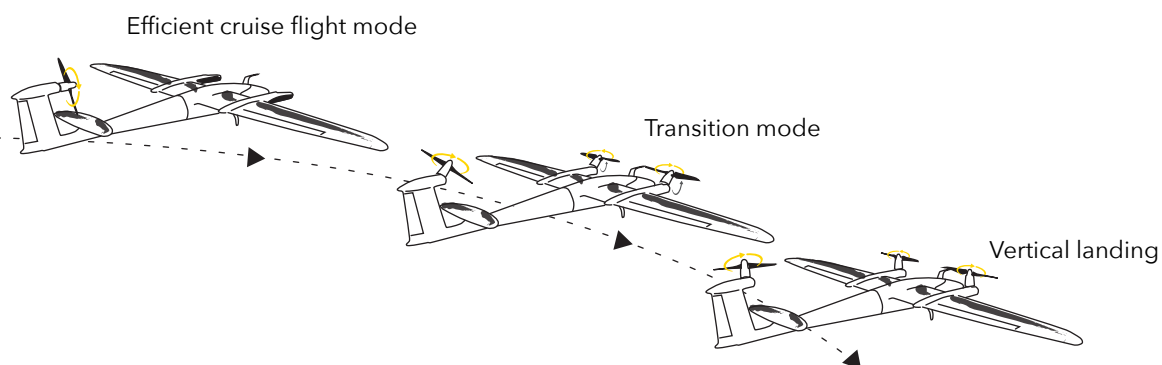

Efficient cruise flight mode. In cruise flight mode, the UAS operates at its aerodynamic efficiency optimum. Only the rear motor operates at a highly efficient low power cruise setting. In this mode the UAS can fly for 90 minutes.

Vertical landing. All three motors are tilted back to vertical position. The UAS lands smoothly and controlled on its shock absorbing landing gear.

R&D

Leading eVTOL fixed-wing UAS engineering

How do we ensure our customers always receive state-of-the-art products? How do we realize short response times to changing market conditions and new customer requirements? How do we achieve cost efficiency and how can we pass this on to our customers in the form of excellent pricing?

The answer is: our highly innovative and agile development cycles, organized in sprint stages, lead to short development times and fast technological advances.

The development of all function and mission critical components and software modules happens in-house. This is crucial for us to achieve comprehensive systems competence in the overall system and applies to the autopilot, flight control computer, sensor data fusion, moding, mission control and flight guidance.

We keep prototype intervals short for fast iteration cycles. This is how we reach a steep increase in technology, product maturity and functional enhancements. Our customers benefit from always having German engineered and state-of-the art products at their disposal.

“With our flying systems there is just one path we follow - striving for excellence in all disciplines and make sure mechanics, avionics, control and operability interact perfectly.

Hence our motto: Do it right - from the beginning. ”

Dr. Michael “Mike” Kriegel,

Senior System Engineer, Team Lead Flight Control & Architecture of System, Quantum-Systems GmbH

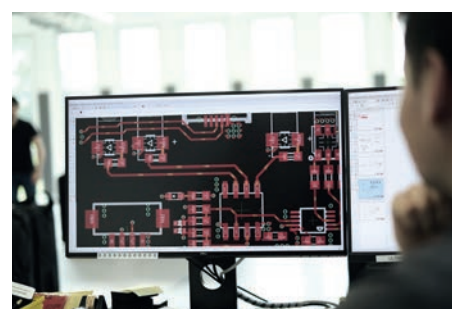
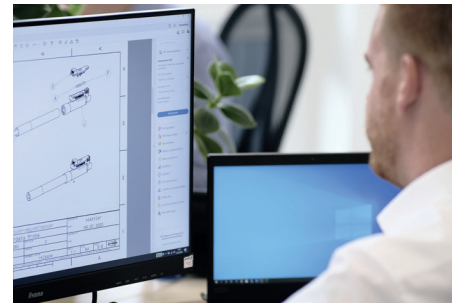

PRODUCTION

Since Quantum-Systems started its operation in 2015 it is our priority to deliver easy to handle, reliable and high-quality UAS for the professional user.

The Quantum-Systems supply chain is optimized for fast and reliable delivery. Major components are provided with a serial number for convenient tracking. We select our suppliers with care, based on their experience and expertise in the respective fields.

The final assembly and testing of our systems are performed in our HQ in Gilching, Germany, by highly skilled drone operators. They apply advanced testing procedures to ensure reliability and quality of our products.

Tron was the first eVTOL fixed-wing UAS developed, produced, and sold by Quantum-Systems. It became the platform for all succeeding developments of Quantum-Systems. Tron can carry payloads and sensors with a weight of up to 2 kg, which is unique in the no-runway drone market.

The first Trinity prototype had its maiden flight in 2016. In 2018, we started serial production of Trinity, mainly made of Elapor™ foam. Multiplex™ - a global renowned brand in model airplanes - is our partner of choice for easing the sourcing process for Trinity.

We are steadily working to increase our production capacities and process quality while shortening the time span from order to delivery.

When we started producing Vector and Scorpion, we are able to look back on a wealth of experience. The Vector is made out of carbon-fiber reinforced material, that makes it more resistant to various weather conditions. When transitioning from prototyping into serial production, we focus on the continuous ramp-up to increase capacities and shorten production lead times while, of course, maintaining our high quality requirements and standards. Since October 2020 we are ISO9001 qualified.



Christoph Muth
Head of Product &
Production

MILESTONES

- 2015.** Maiden flight Tron.
- 2016.** → Market release and production of Tron.
→ Maiden flight Trinity.
- 2018.** Market release and start of serial production of Trinity V1.
- 2019.** Introduction of Trinity F90+ product updates and volume increase.
- 2020.** → Start of production in new HQ facilities, with state-of-the-art fabrication according to customer requirements.
→ Start of serial production of Vector and Scorpion 2-in-1 System.
→ ISO9001 certification

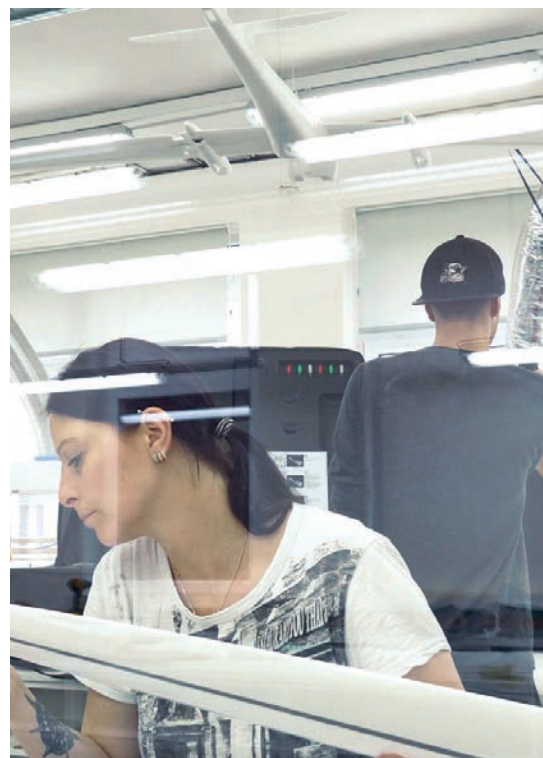

TRINITY F90+



TRINITY F90+

eVTOL. Fixed-wing. Mapping UAS.

Starting with the first version of the Trinity in 2016, we provided the basis for a highly efficient and at the same time affordable VTOL UAS without compromising on features. The Trinity F90+ leverages this platform and improves many aspects to offer professional users even more functionality at an unbeatable price.

The perfect weight balance keeps the rear rotor, which is solely used for the cruise flight during the mission, in the ideal thrust-to-size ratio in both VTOL and forward flight modes. The Trinity F90+ uses less energy, achieves longer flight times and thereby shows its outstanding value compared to other drones.

Our Trinity F90+, due to its refined aerodynamics, reaches a flight time to 90 minutes. This makes it the system of choice for the broad variety of mapping and surveying applications. Flying large areas (700 ha / 1730 acres) or long distances (100 km / 62 miles) per flight is easy with this efficiently working transition aircraft.

In order to collect aerial data to make better decisions we support our customers' missions by the continuous integration of high precision sensors into our drones. This gives our customers the flexibility to choose the payload that perfectly fits their daily needs.

FEATURES

- 90+ minutes flight time
- High precision sensors
- PPK including Quantum-System iBase ground reference Station
- Best-in-class sensors including dual RGB & Multispectral payload and 42 MP HighRes RGB
- Powerful motors for even more reserves in all situations
- Live Air Traffic (ADS-B IN) incl. QBase 3D Mission Planning
- 2.4 Ghz telemetry with up to 7 km command & control and optional ADS-B OUT Mode-S Transponder



TECHNICAL DATA

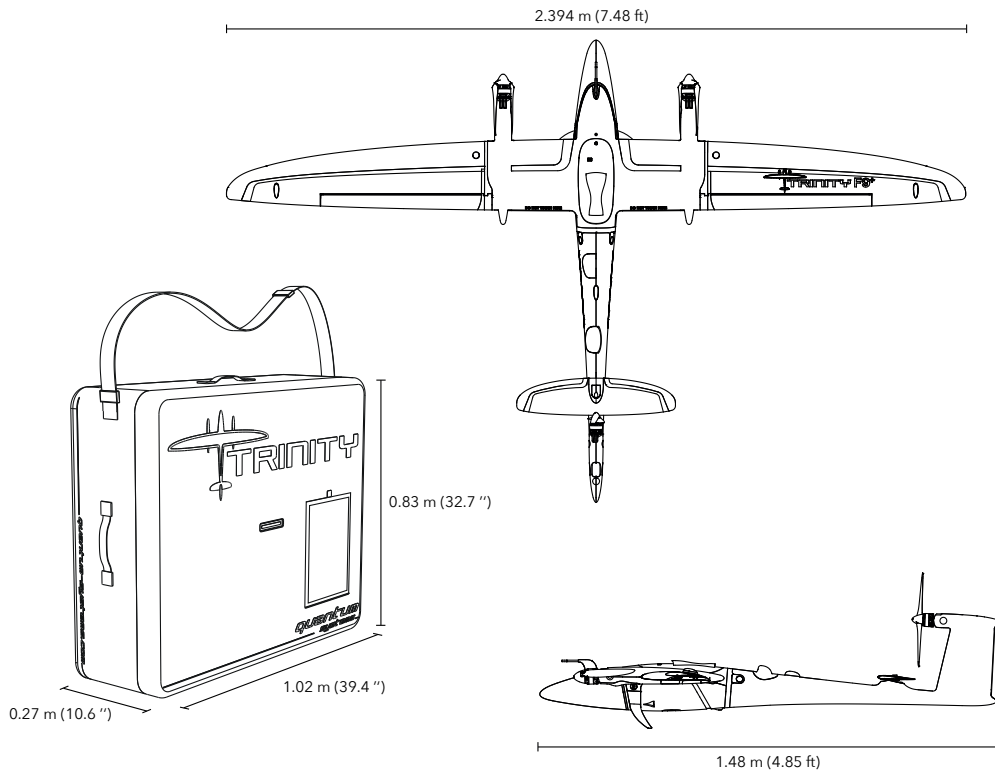

Trinity F90+

Max. Take-off Weight	5.0 kg (11.0 lbs)	1 Subject to export regulation, may require export permission.
Max. Flight Time	90+ min ¹	2 Please be aware that the flight time and max. wind tolerance are reduced with increasing flight altitude. Depending on the weather conditions; tested at 15° C (59° F). For further details read the user manual chapter 3.1.
Max. Range = Max. Coverage	100 km = 700 ha	
Maximum Flight Altitude (MSL)	4500 m (14763.8 ft) ²	
Command and Control Range	5 - 7.5 km ³ (3.1 - 4.7 mi)	
Payload	max. 700 g (1.54 lbs)	3 Please be aware that the max. wind tolerance is reduced with increasing flight altitude.
Optimal Cruise Speed	17 m/s (33 kn)	
Wind Tolerance (ground)	up to 9 m/s (17.5 kn) ³	4 Please follow the local regulations for the maximum allowed transmission power.
Wind Tolerance (cruise)	12 m/s (23.3 kn)	
Battery Weight	1.5 kg (3.3 lbs)	5 For outside temperature < 10° C (< 50° F): • Heat up the battery to 25° C (77° F) for at least 5 hours For outside temperature < 0° C (< 32° F) the flight time will be reduced to max. 70 minutes.
Telemetry link & RC Transmitter Frequency	2.4 GHz	
Telemetry link (QBase Modem) Power	max. 100 mW ⁴	
Operating Temperature Range	-12° C to 50° C (10.4° F to 122° F) ⁵	
Wingspan	2.394 m (7.85 ft)	
Transport Case Dimension	1002 x 830 x 270 mm (39.4 x 32.7 x 10.6 inch)	



SCENARIOS



Mapping

- Geo-referenced aerial images
- Surface models
- Point cloud
- Distance and volume measure
- Land and infrastructure environment
- Archeological surveys and excavation monitoring



Inspection

- Thermal inspection
- Optical inspection
- Multispectral inspection
- Crop inspection



Agriculture

- Pest infestation detection
- Quantity moisture levels
- Analyze wildlife damage
- Vegetation index creation like NDVI
- Crop counting



Mining

- Site planning
- Contour maps
- Stockpile and slope analysis
- High accuracy without GCPs
- Safe landing despite rough terrain



Monitoring

- Mine or quarry monitoring
- Land cover classification
- Monitoring and documentation of the construction progress
- Monitoring of linear infrastructure



Industrial

- 3D models of sites
- Aerial inspection
- Construction site surveys



SENSORS

Sony UMC 20 mm

Spectral Channels:
RGB
Resolution (@100m AGL):
2.1 cm (20.1 MP)



Sony UMC 16 mm

Spectral Channels:
RGB
Resolution (@100m AGL):
2.6 cm (20.1 MP)



Sony RX1RII.

Spectral Channels: RGB
Resolution (@100m AGL):
1.3 cm (42.0 MP)

Double Payload

Sony UMC + TX Thermal 19 mm







Sensor Format: 640 x 512
Field of View: 32° x 26°
Frame Rate: 8.33Hz
Spectral Band 7.5 - 13.5 μm





LiDAR Qube 240

Spectral Channels:
LiDAR
Resolution (@100m AGL):
50 - 100 points per m²

Sensors and their application

Application Scenarios	Sony UMC	Sony RX1RII	Sony UMC + TX Thermal	LiDAR Qube 240	Mica Sense RedEdge-MX	Sony UMC + RedEdge-MX	Mica-Sense RedEdge-MX Dual	Mica-Sense Altum
 Mapping	●	●				○		
 Mining	●	●		○				
 Inspection	●	●	●	●	○	●	○	○
 Monitoring	●	●		○		●		●
 Agriculture					●	○	●	●
 Industrial	●	●	●	●				○

○ = optional choice
● = perfect choice

	<p>Double Payload Sony UMC + MicaSense RedEdge-MX Spectral Channels: RGB & RGB NIR RE Resolution (@100m AGL): 2.6 cm (20.1 MP) + 7cm per band</p>		<p>MicaSense Altum Spectral Channels: RGB NIR RE / LWIR: thermal infrared 8 - 14 μm Resolution (@100m AGL): 4.3 cm per band ca. 60 cm thermal</p>
<p>MicaSense RedEdge-MX Spectral Channels: RGB NIR RE Resolution (@100m AGL): 7 cm per band</p>		<p>MicaSense RedEdge-MX Dual Spectral Channels: RGB NIR RE Resolution (@100m AGL): 7 cm per band</p>	

Payload Compartment

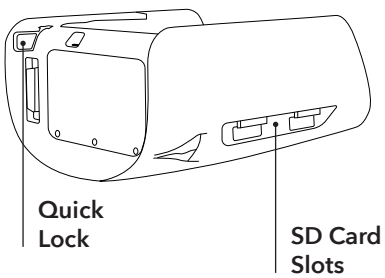

Camera integration done right - easily exchangeable and accessible

Easy payload swapping. Payloads can easily be swapped in seconds by using the Quick Lock mechanism. No tools are required and the sensors are highly integrated to support the pilots' mission planning.

Easy access to your data. Access to the recorded data is uncomplicated via external card slots.

Payload damping. All cameras are damped against in-flight vibrations to guarantee highest image quality.

No belly landings. Rough landings should be avoided at any time. We unconditionally rely on vertical take-off and landing to guarantee smooth landings and therefore a long service life. The landing gear additionally supports the safety of the components by offering additional flex.

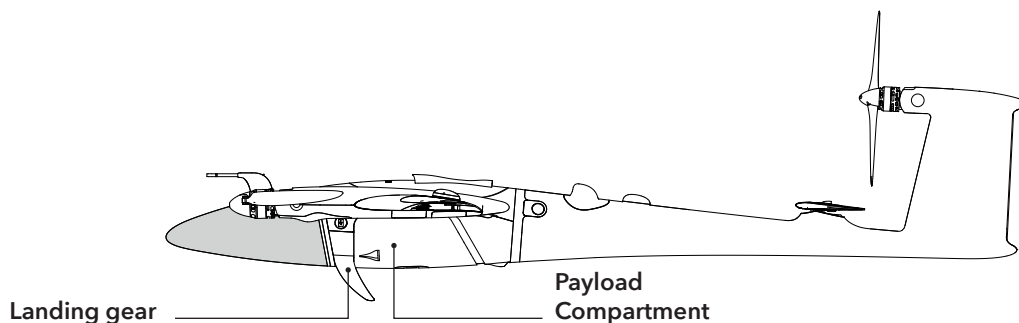

HIGH VALUE DATA OUTPUT

PPK accuracy. Large coverage. High resolution.

PPK capability in every situation. PPK and RTK (post-processing kinematics and real-time kinematics) are the algorithms that allow the user to cancel most of GNSS errors via processing data from two receivers that are close enough to each other. They share the same common errors for most error sources such as ionospheric and tropospheric influence on the signal transmission, satellites ephemeris and clock errors. As it is clear from the names, RTK is performed in real time, PPK - in post-processing. When properly applied, these algorithms reduce positioning errors from several meters (typical for standalone GNSS receivers) down to centimeters.

Geo referencing on the go with the Quantum-Systems iBase included. iBase is an entry level GNSS reference station. It automatically logs GNSS reference measurements on the ground to a file on a micro SD card. This file enables the post processing software to do PPK processing of the data collected in flight. All Quantum Trinity F90+ Systems are equipped with the accessories necessary for doing PPK. This includes iBase, cabling and QBase 3D software for post processing.

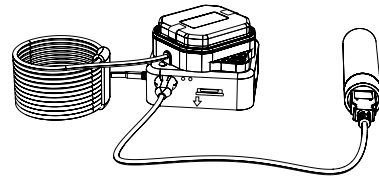

Geotagging of flights with various post processing options. Our software QBase 3D supports RINEX files (Receiver Independent Exchange Format e.g. RINEX 2 and RINEX 3) from various sources for the PPK process in planning and postprocessing.

The correction file for the PPK process can either be supplied by the base station iBase or a base station of another manufacturer like Trimble, Topcon or Leica. RINEX data from virtual reference stations of national data providers are also supported.

PPK ACCURACY

PPK enables the geotagging relative precision of down to 2 - 5 cm in respect to the antenna placement point. With the provided iBase it is especially easy. Just power up the station and it does the rest.

Accuracy without PPK

Trinity F90+
Sony RX1 RII

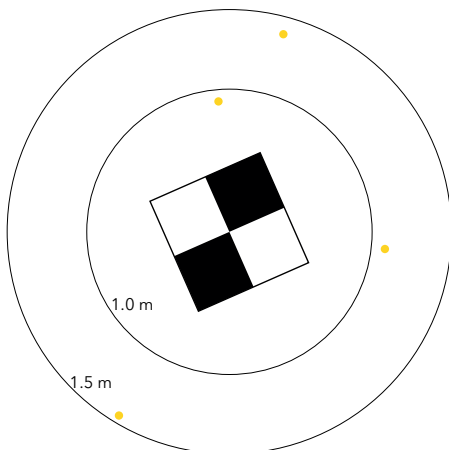

Accuracy with PPK

Trinity F90+
Sony RX1 RII

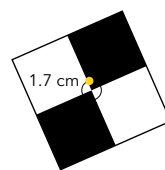

● GCP (survey grade
Ground Check Point)

LARGE COVERAGE

More survey data in less time. Whether in the agricultural sector, in the mining business or when inspecting industrial plants and construction progress, more data can be recorded in shorter time than it was previously possible with conventional systems. The Trinity F90+ demonstrates its range advantage in comparison to classic multicopters and other fixed-wing drones due to the longer flight time and covers up to 20x larger areas. The larger the area to be covered, the more attractive the use of the Trinity F90+ gets.

With the Sony RX1R II (42 MP) or Sony UMC-RC10 (20.1 MP), the Trinity F90+ provides ideal payload configurations to efficiently map large landfills, gravel pits, open pit mines or construction sites in high resolution. Together with its high PPK accuracy very precise data sets like orthomosaics, DTMs (digital terrain model), DSMs (digital surface model), stockpile volumes or excavation volumes can be created.



Coverage 81 ha / 200 acres
GSD 1.29 cm / 0.4 inch / px
Camera Sony RX1RII
Altitude 100 m / 330 ft AGL

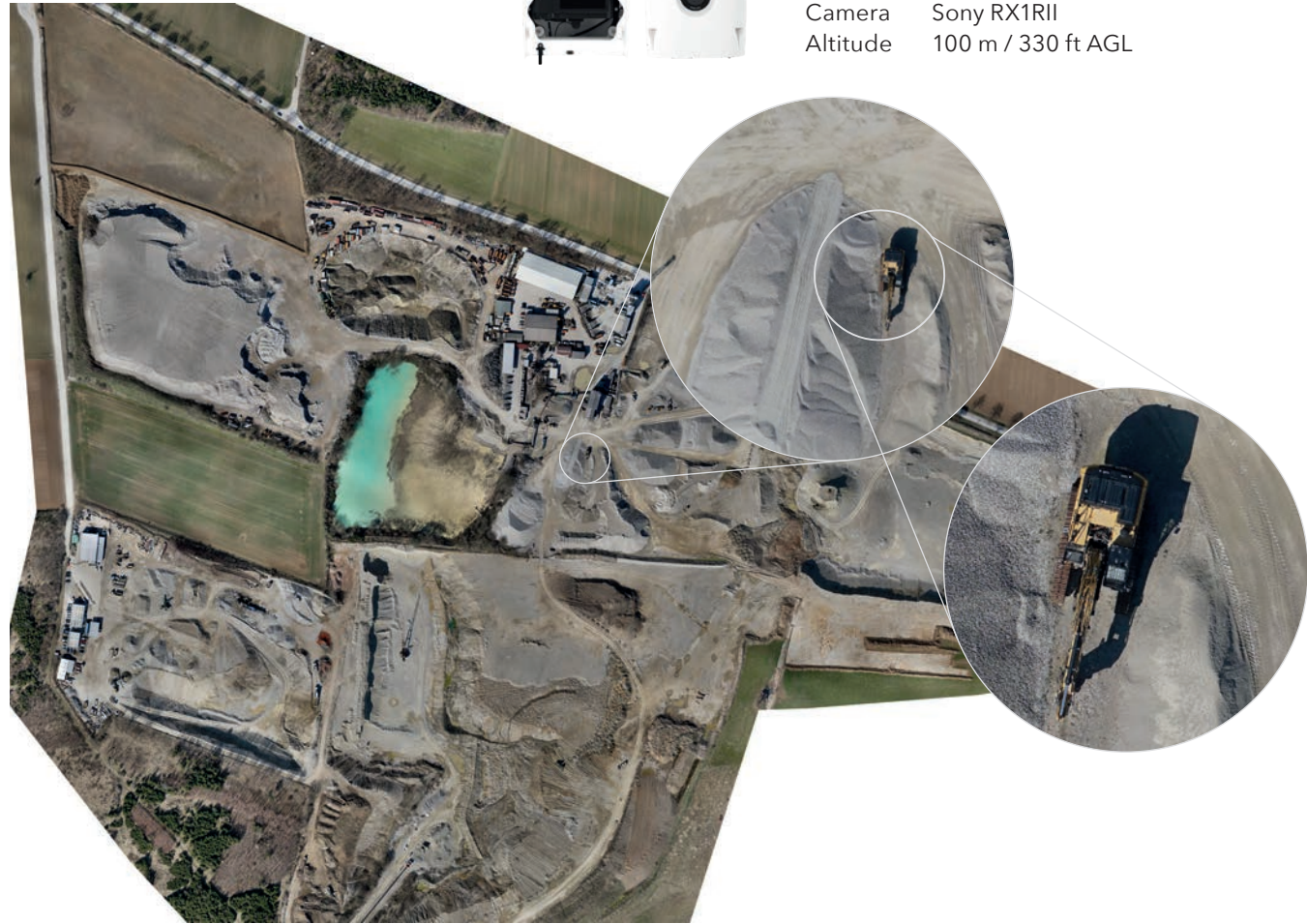

Sony UMC-R10C	
GSD	3.2 cm / 1.26 inch / px
Coverage	700 ha / 1729 acres
Camera	Sony UMC-R10C 20 MP RGB
Altitude	120 m AGL

Sony RX1R II - Large area	
GSD	3.2 cm / 1.26 inch / px
Coverage	1050 ha / 2594.6 acres
Camera	Sony RX1 RII 42 MP RGB
Altitude	250 m AGL

Sony RX1R II - High resolution	
GSD	1.55 cm / 0.6 inch / px
Coverage	550 ha / 1359 acres
Camera	Sony RX1 RII 42 MP RGB
Altitude	120 m AGL





WE ARE THE QUANTUM-SYSTEMS FAMILY

VECTOR & SCORPION



THE 2-IN-1 SYSTEM

eVTOL. Fixed-Wing & Tri-Copter. The ultimate ISR System.

The mathematical definition of a vector fits very well for the latest UAS from Quantum-Systems. It can face any direction: upwards, forwards or downwards. That's exactly what Vector from Quantum-Systems is capable to do: vertical take-off, energy efficient long range fixed wing flight and back to a vertical landing. All automatic, no pilot or operator input needed.

Vector - long endurance fixed-wing UAS. Flexible and enduring, the Vector provides flight and surveillance characteristics that are exceeding performance of current UAS platforms in service all over the world.

The ability to operate in the most difficult terrain combined with extremely low noise emission (silent mode) makes the Vector the perfect UAS for a wide range of non-invasive operations. The encrypted mesh IP link sends video streams up to a range of 15+ km and is tested and proven under harsh operating conditions. The flight time of up to 120 minutes speaks for itself. All combined in a compact and robust electric VTOL UAS.

Scorpion - short endurance tri-copter UAS. The Scorpion impresses with the same mesh IP encrypted HD data link with an operating range of up to 15+ km. As a tri-copter, it is ideal for smaller-scale and stationary use, for example in densely built-up urban areas. With a flight time of 45 minutes, it can cover a wide range of civil applications.

2-IN-1. The 2-in-1 System design opens up further applications with the Scorpion configuration - by removing the wings and attaching a separate set of copter arms a dedicated multi-copter platform becomes available for an even wider variety of mission applications. Either use a VTOL fixed-wing or a conventional copter - in both cases you only need one system to train on and to deploy it on site.

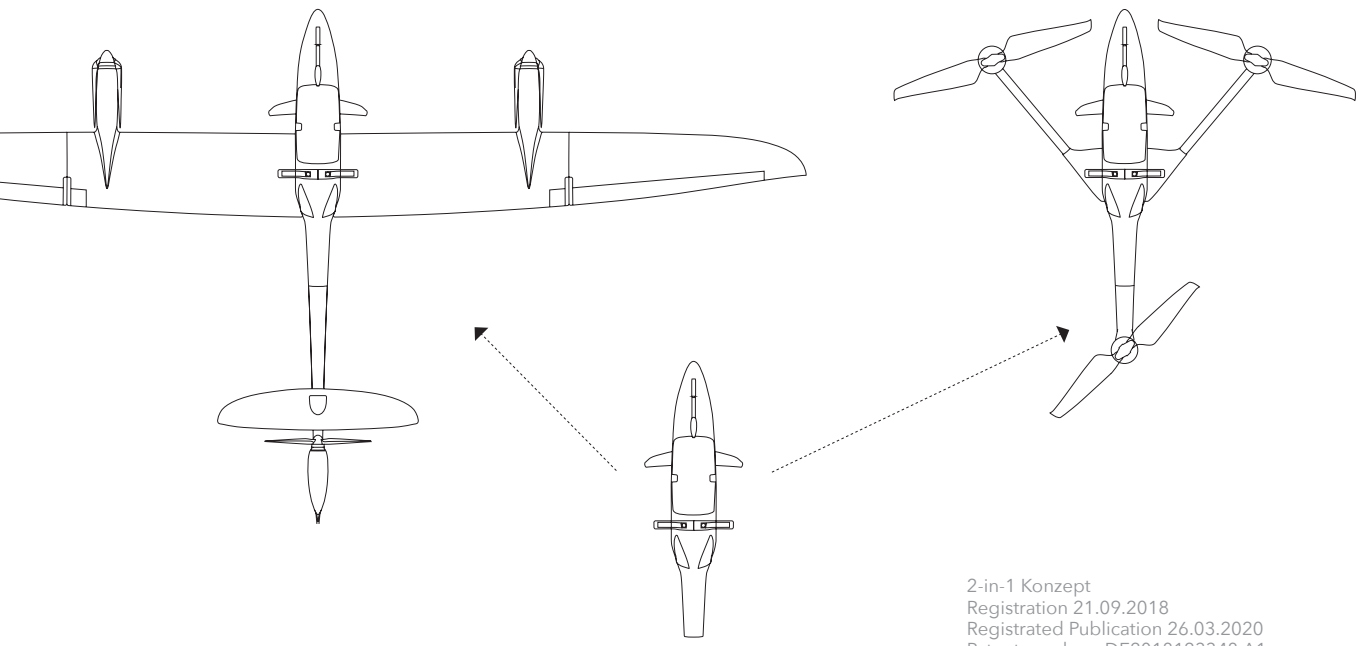

2-in-1 Konzept
Registration 21.09.2018
Registered Publication 26.03.2020
Patent numbers DE2018123348 A1

TECHNICAL DATA

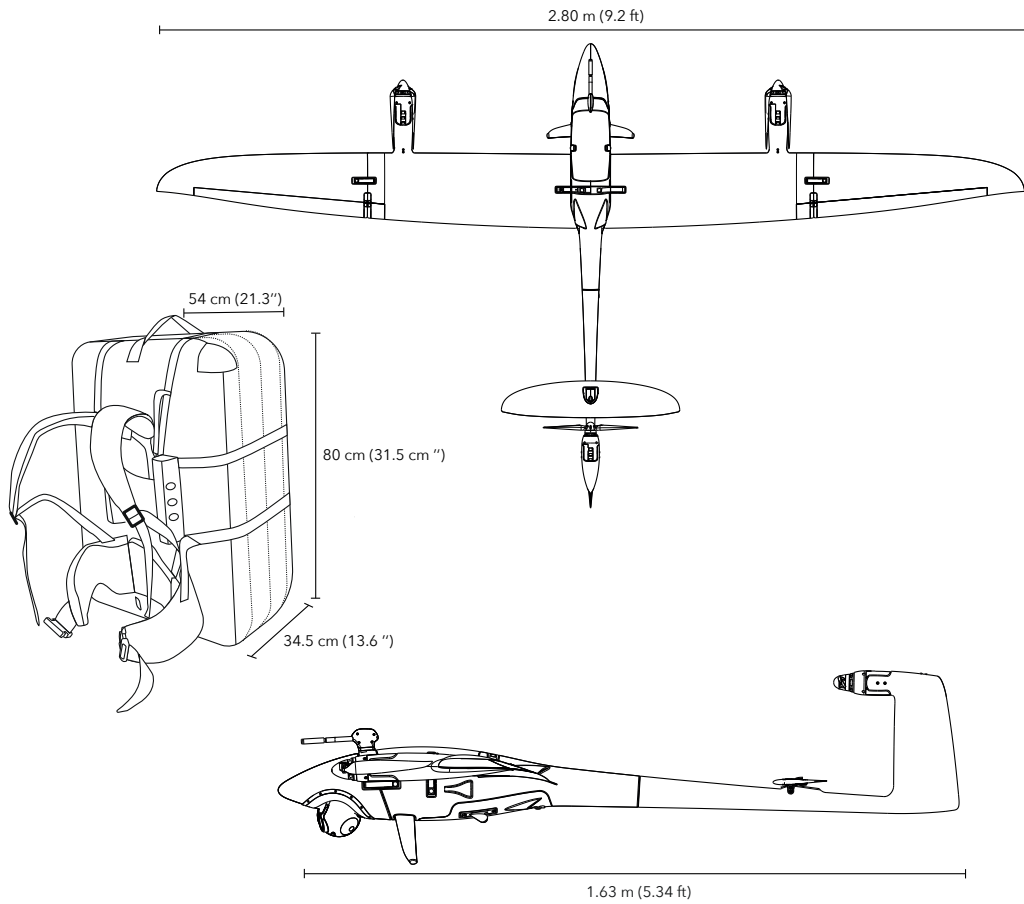

Vector™

Max. Take-off Weight	7.4 kg (16.3 lbs)
Max. Flight Time	120 min
Maximum Flight Altitude (MSL)	3000 m (9842 ft)
Command and Control Range	15 - 25 km / 9.3 - 15.5 mi (Ground link dependent)
Video Link Range	15 - 25 km / 9.3 - 15.5 mi
Cruise Speed Range	15 - 20 m/s (29 - 39 kn)
Optimal Cruise Speed	15 m/s (29 kn)
Wind Tolerance (ground)	10 m/s (19 kn)
Wind Tolerance (cruise)	12 m/s (23.3 kn)
Wingspan	2.80 m (9.2 ft)
Backpack Size	80x54x34.5 cm (31.5"x21.3"x13.6")
Backpack Weight	9.2 kg (20.3 lb) Cover incl. foam inlay.



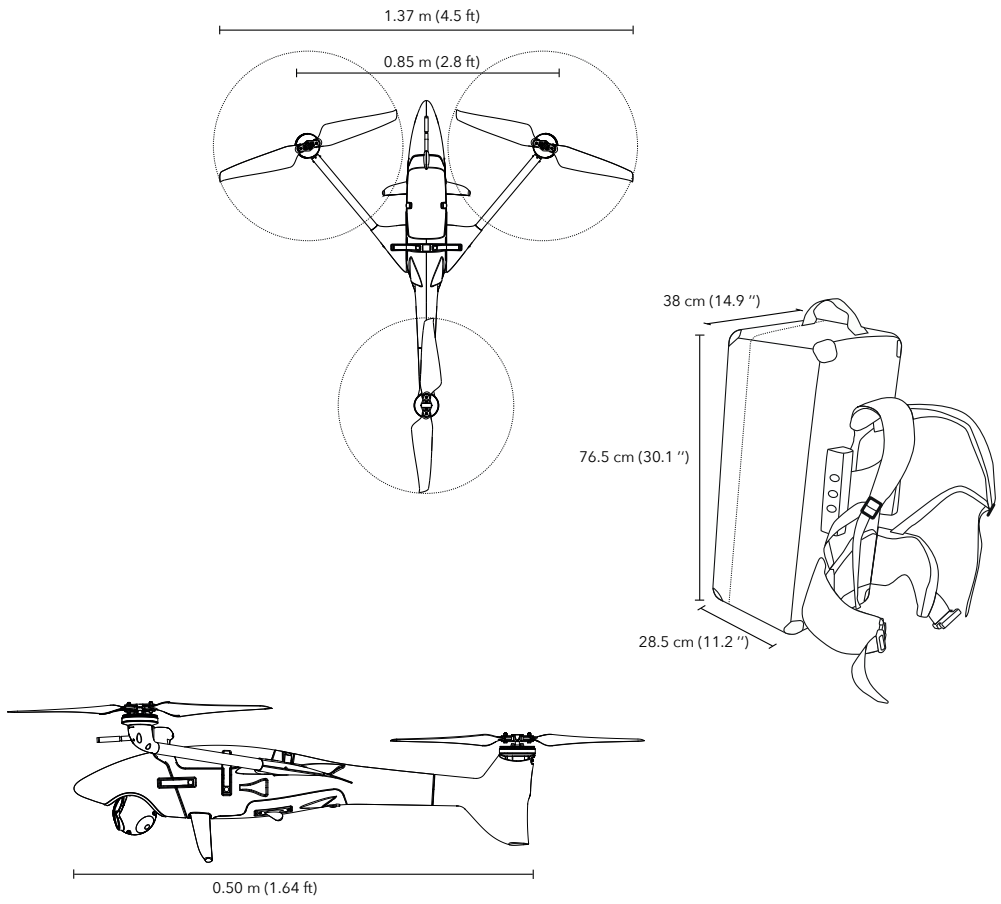

Scorpion™

Max. Take-off Weight	<5 kg (<11 lb)
Max. Flight Time	up to 35 min
Maximum Flight Altitude (MSL)	3000 m (9842 ft)
Command and Control Range	15 - 25 km / 9.3 - 15.5 mi (Ground link dependent)
Video Link Range	15 - 25 km / 9.3 - 15.5 mi
Cruise Speed Range	0 - 15 m/s (0 - 29 kn)
Wind Tolerance (ground)	10 m/s (19 kn)
Wind Tolerance (cruise)	10 m/s (19 kn) (gusts: 12 m/s (23.3 kn))
Wingspan (without propellers)	0.85 m (2.8 ft)
Length (with propellers)	1.37 m (4.5 ft)
Backpack Size	76.5x38x28.5 cm (30.1"x14.9"x11.2")
Backpack Weight	5.7 kg (12.6 lb) Cover incl. foam inlay





KEYFACTS 2-IN-1

- Mission ready in less than 2 minutes, only one operator needed
- Payload & all general parts with quick lock mechanism (no tools needed)
- Fiber reinforced airframe and shock absorbing landing gear
- Sophisticated cooling system for data link & electronics
- Detachable gimbal
- Mesh IP encrypted data link with a range of 15+ km
- Selfheated batteries for cold temperature operations

SCENARIOS



Law Enforcement

- (Auto) Tracking of vehicles and persons with AI
- Zoom-in function to identify license plates and suspicious objects
- IR capabilities offers mission performance by night
- Very low noise emission



Tethered Monitoring of Events & Masses

- Crowd control and event surveillance
- Unlimited endurance and secure data connection
- Situational awareness



Search & Rescue

- Identifying burried and hidden victims
- Dual payloads offer day and night capabilities



Traffic Investigation

- Coordinate first responders
- Identify fast access routes
- Monitoring traffic jams
- Identifying alternative traffic routes



Anti Poaching

- Monitoring wildlife
- Identify hidden people with IR
- Geotagged video stream offers position data for park rangers



Fire Fighting

- Guide fire fighters from air
- Identify glowing nests with thermo sensor



SENSORS



HD40-LV

Dual EO/IR Gimble for day and night view with 10x zoom



HD40-XV

EO only configuration with 30x zoom
Only for Scorpion

All sensor changes are done by easily exchanging the nose section of the centerpiece in a matter of seconds. No tools required.

Observing targets at day and night with IR capability (EO / IR option) gives you all the flexibility needed. Reading license plates at up to 700 m distance with EO 30x zoom option or marking targets at night with IR illuminator (laser option) increase your operational success.

	HD40-LV	HD40-XV	Nighthawk2 UZ
EO Zoom	10x optical, 2x digital	30x optical, 2x digital	20x optical, 2x digital
EO Resolution	1280 x 720 px	1280 x 720 px	1280 x 720 px
IR Zoom	4x digital	N/A	4x digital
IR Resolution	640 x 480 px	N/A	1280 x 720 px
Data rate	5 Mb/s (H264)	5 Mb/s (H264)	5 Mb/s (H264)
Power consumption	15 W	20 W	7W
Weight	600 g / 1.3 lb	800 g / 1.7 lb	350 g / 0.8 lb
MISC	KLV-Stream, GeoLock, Image stabilization, Object tracking	KLV-Stream, GeoLock, Image stabilization, Object tracking	KLV-Stream, GeoLock, Image stabilization, Object tracking



Nighthawk2 UZ



Dual EO/IR Gimbal for Day and Night view with 20x zoom



High Res. Tactical Mapping & LIDAR

Coming soon

Sensors and their application

Application Scenarios	HD40-LV	HD40-XV	Nighthawk2 UZ	Coming soon High Res. Tactical Mapping & LIDAR
 Law Enforcement	●	●	●	
 Monitoring of Events	○	●	○	
 Search & Rescue		●	●	●
 Traffic Investigation		●	●	
 Anti Poaching	●		●	●
 Fire Fighting	●		●	●

○ = optional choice

● = perfect choice

FUTURE-PROOF

To give customers greater flexibility on the software side, Quantum-Systems partners with Auterion and combines the best-in-class sUAS hardware with the secure, scalable, open source Auterion software platform. We offer our customers the choice between running the proprietary Quantum-Systems software or using the Auterion Enterprise stack based on open source technology (PX4, MAVSDK, QGC) and open industry standards (Pixhawk, MAVLink).

Using the Auterion software platform, Quantum-Systems UAS are compatible with the U.S. DoD's Blue sUAS architecture. From now on Vector and Scorpion customers will have this freedom of choice.



Auterion

Making Vector & Scorpion part of an ecosystem

Auterion are leaders in an open source movement bigger than themselves that works together to meet the needs of enterprises and government. Auterion believes in openness, partnership, engineering excellence, and empowering the drone industry.

They have been on the same mission for over a decade. Their story began with Pixhawk in 2008 and the revolutionary PX4 software created by the co-founder Lorenz Meier, now the most widely used open-source drone autopilot operating system.

Auterion's software platform is powering the Quantum-Systems Vector and Scorpion sUAS, aligning them with the requirements of the US Defense and Security market.

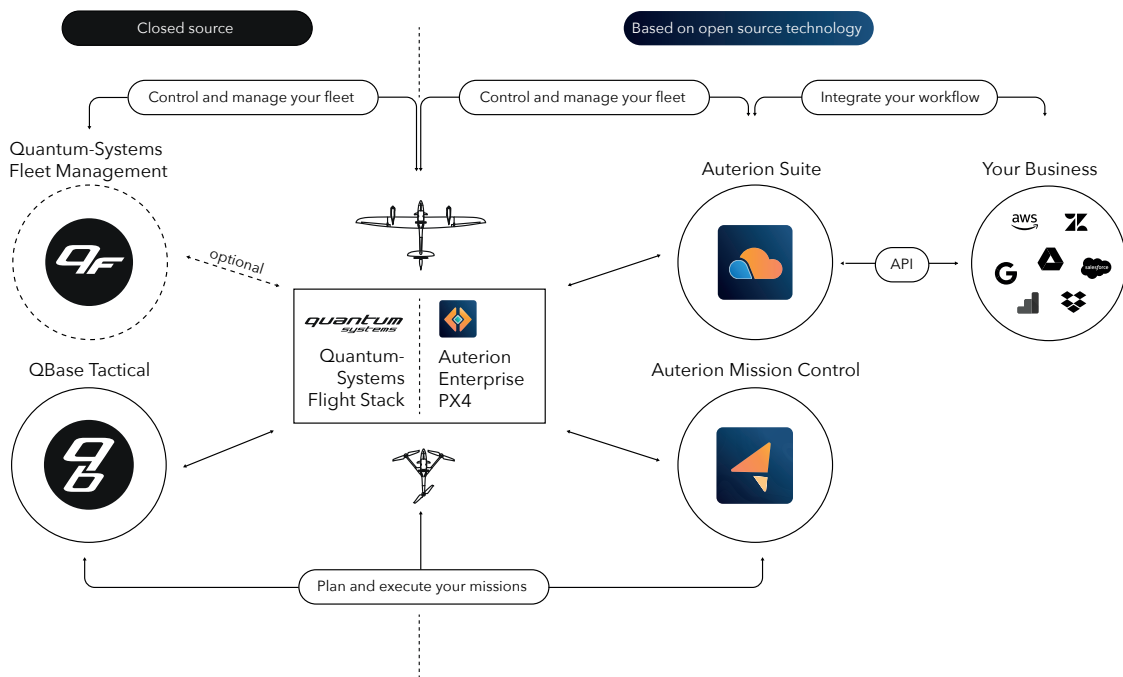

QUANTUM-SKYNODE

Powered by Auterion

Based on Auterion’s reference design, Quantum-Systems created their customized version of Skynode – the Quantum-Skynode.

The Quantum-Skynode autopilot hardware and software module enables sUAS autonomy through a fusion of precision navigation, computer vision processing including state of the art AI, and advanced networked communications. Running the Quantum-Systems proprietary software technology it enables interaction with closed as well as open standards. It protects customer requirements with a highly interoperable platform interface capability. Following reference standards and being aligned with the U.S. DoD’s Blue sUAS architecture, the Quantum-Skynode is predestined and made to run the Auterion software stacks.

A wide variety of payloads can be connected and interfaced via Ethernet, USB, CAN, or UART on a single connector. Payloads and video can be configured, operated, and interactively viewed from the ground with Quantum-Systems QBase Tactical or Auterion Mission Control.

Quantum-Skynode connects Vector and Scorpion with either QBase Tactical or Auterion Mission Control. Either way, you will get workflow integration, advanced autonomy features, mission planning, live video streams, operations dashboards, flight analytics and predictive maintenance.

KEY FEATURES

- Combines flight controller, mission computer and connectivity
- Obstacle avoidance, collision prevention and VIO (Auterion)
- Ready to integrate UTM and remote ID
- SDK to control data and drones from your own apps (Auterion)
- Enabling state-of-the-art AI applications
- Operate gimbals and cameras via flexible PPB interface
- View live video streams on QBase Tactical or Auterion Mission Control

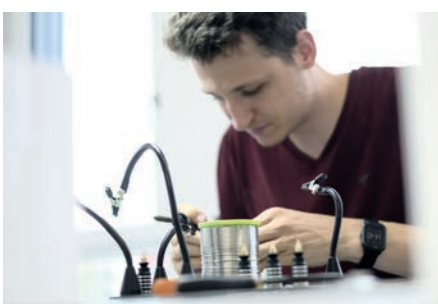
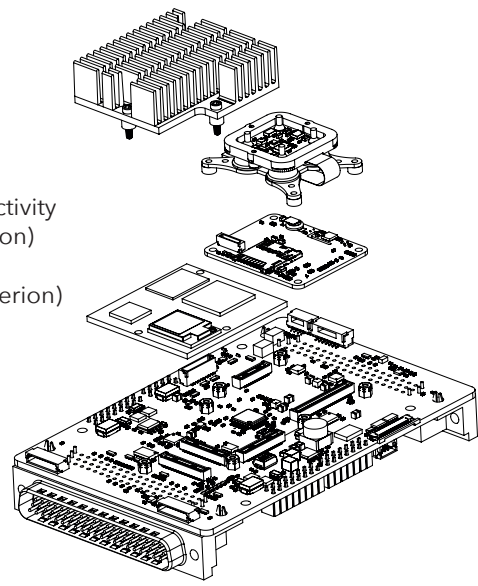

OBASE 3D



QBASE 3D

Mission Planning. Flight Monitoring. Data Post-processing.

QBase 3D is the most convenient platform to plan aerial survey missions with Quantum-Systems UAS. It automatically generates efficient flight paths after the observation areas and the mission parameters have been defined with just a few clicks. This allows the operator to be up and flying within no-time, saving valuable resources. For advanced missions, the pilot is in complete control over the photogrammetric aerial survey mission and can adjust all relevant parameters to generate professional and optimum results.

During flight mode, QBase 3D provides accurate information on aircraft and mission status to ensure flight safety and mission success.

After mission completion, QBase 3D enables processing of the captured images, precision enhancement with the built-in PPK solution and export of all metadata to file formats suitable for a variety of platforms for further post-processing.

BENEFITS

More safety through 3D planning. The integrated 3D view is an efficient tool to plan precisely and to keep the overview during flight.

Various applications supported. The combination of Quantum-System UAS with QBase 3D helps surveyors, farmers, scientists, quarrymen, civil engineers, and geologists to focus on their professional application.

Easy to stay up to date. QBase 3D automatically notifies you when a new software release is available. The update can be done simply by the click of a button.

Simple and fast operation. All mission relevant steps from planning to flying can be carried out intuitively.

PPK Data Processing. Easily export your PPK processed data with direct compatibility of Pix4D, AgiSoft, Propeller and Trimble Business Center for further post-processing.

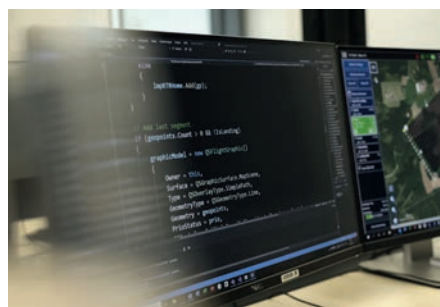

FEATURES

- Corridor planning
- Live-air-traffic
- Resume mission
- Flight simulation
- Mission safety evaluation
- Flight data monitoring
- Battery monitoring
- ESRI map data
- Offline mode



WORKFLOW



Mission Preparation. Select a payload and the presets for data accuracy and define a mission area with just a few clicks. QBase 3D calculates the mission including the necessary flight legs. The final mission check ensures all parameters are correct. It's that easy.



Flight & Landing. There is no pilot interaction necessary while airborne. If circumstances require you to alter the flight path, e.g. an evasive maneuver, you can take over manually using the RC or ground station. The UAS will resume the mission afterwards. QBase 3D always shows the UAS telemetry data, like speed, position, state of battery charge, and pictures taken to ensure mission success.



UAS Take-off. Follow the UAS setup procedure. After connecting the battery and booting the UAS, the mission can be transferred wirelessly to the autopilot. During the preflight check, the autopilot will verify and approve the mission. The VTOL capability requires no additional equipment or interaction, just launch the system by the push of a button.



Data Processing with QBase 3D. The flylogs are downloaded to a PC that is connected to the UAS after landing. With the help of this data it is possible to geotag the imagery files on the SD-Card. The geotagged photos are the basic framework for every data analysis with 3rd party programs. Alternatively, QBase 3D supports export of all relevant data to various post-processing applications in their native format.

QBASE TACTICAL

ISR Missions. Real-time reconnaissance. After action analysis.

QBase Tactical was designed to meet the highly demanding requirements of governmental agencies, like law enforcement or the military. It supports QuickStart missions, with no prior planning required. Just power up the aircraft and take off.

The change between Vector and Scorpion configuration is automatically detected and supported seamlessly with automatic adjustment of flight and mission parameters. The same applies when the payload on the UAS is exchanged.

QBase Tactical allows intuitive control of aircraft and sensor via hardware joysticks, clicks on the map or in-flight mission updates. Sensor data is immediately displayed and enhanced with additional metadata to increase situational awareness and mission success.

All aircraft or sensor data received on the Ground Control Station (GCS) is stored in one database per mission. This supports in flight replays, the review of critical events, as well as after flight analysis. A data-base file can be enhanced with markers on the map and in the sensor image during flight or afterwards and shared with third parties. In addition, export of still images and videos is possible.

QBase Tactical helps covertly operating UAS pilots in multiple ways. Automatic tracking and guidance modes let the aircraft follow your target with a programmable distance to ensure image quality, while minimizing risk of detection. Display of wind direction, sound level and aircraft shadow on the ground supports you to fulfill each mission undetected.

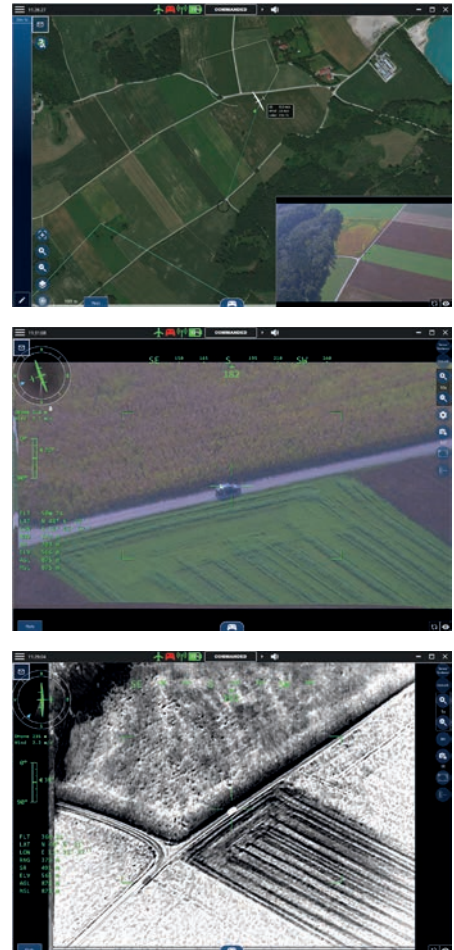

CUSTOMER SUPPORT

Knowledge. Support. Training. Repair.

We accompany our customers and stand by our products every step of the way. We help where needed. Customer feedback drives us to new top performances.

Support. We have 70+ officially licensed Quantum-Systems resellers around the globe. They are your local point of contact in case you need support (1st level). Quantum-Systems provides 2nd level support for all Quantum-Systems products like Trinity F90+, Vector, Scorpion, QBase 3D, QBase Tactical out of our Headquarter in Germany. With our advanced digital helpdesk ticketing platform, we ensure a fast, transparent and useful processing of each support request. In addition we provide 24/7 digital access to all relevant and helpful documents.

Contact channels for our resellers. Helpdesk · Mobile · Phone · Mail · Messenger
General office hours. 8:30 am – 5:30 pm (Berlin time)

Global reseller network. www.quantum-systems.com/find-a-dealer/

Training. To make sure your missions are successful we offer comprehensive training on UAS operation as well as on data post-processing (Pix4D, Agisoft, Propeller, and more). We offer our trainings for groups as well as for individuals, both, on-site and via webinars. You can find a large collection of video tutorials on our YouTube channel.

Repair. Our products are covered by a 12 months warranty. In case it's needed, UAS repairs are done by our professional Quantum-Systems repair department in Germany. We train and enable our resellers on a regular basis to execute minor repairs themselves locally, like exchanging propellers and other parts. This reduces shipping costs and waiting time for the UAS user.



FOLLOW US ON

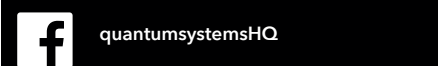
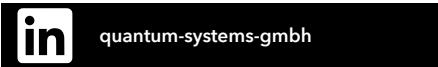

CONTACT US



www.quantum-systems.com/contact



quantum
systems

www.quantum-systems.com